



**TRASPORTO IMBARCAZIONI
TRANSPORTING BOATS
TRANSPORT D'EMBARCATIONS
DEN BOOTSTRANSPORT**



CRESCI
RIMORCHI

www.crescirimorchi.it



**PRINCIPALI ACCESSORI E
CARATTERISTICHE
(A RICHIESTA)**

**MAIN ACCESSORIES AND
FEATURES
(OPTIONAL)**

**PRINCIPAUX ACCESSOIRES ET
CARACTÉRISTIQUES
(À LA DEMANDE)**

**HAUPTZUBEHÖR UND
EIGENSCHAFTEN
(AUF WUNSCH)**

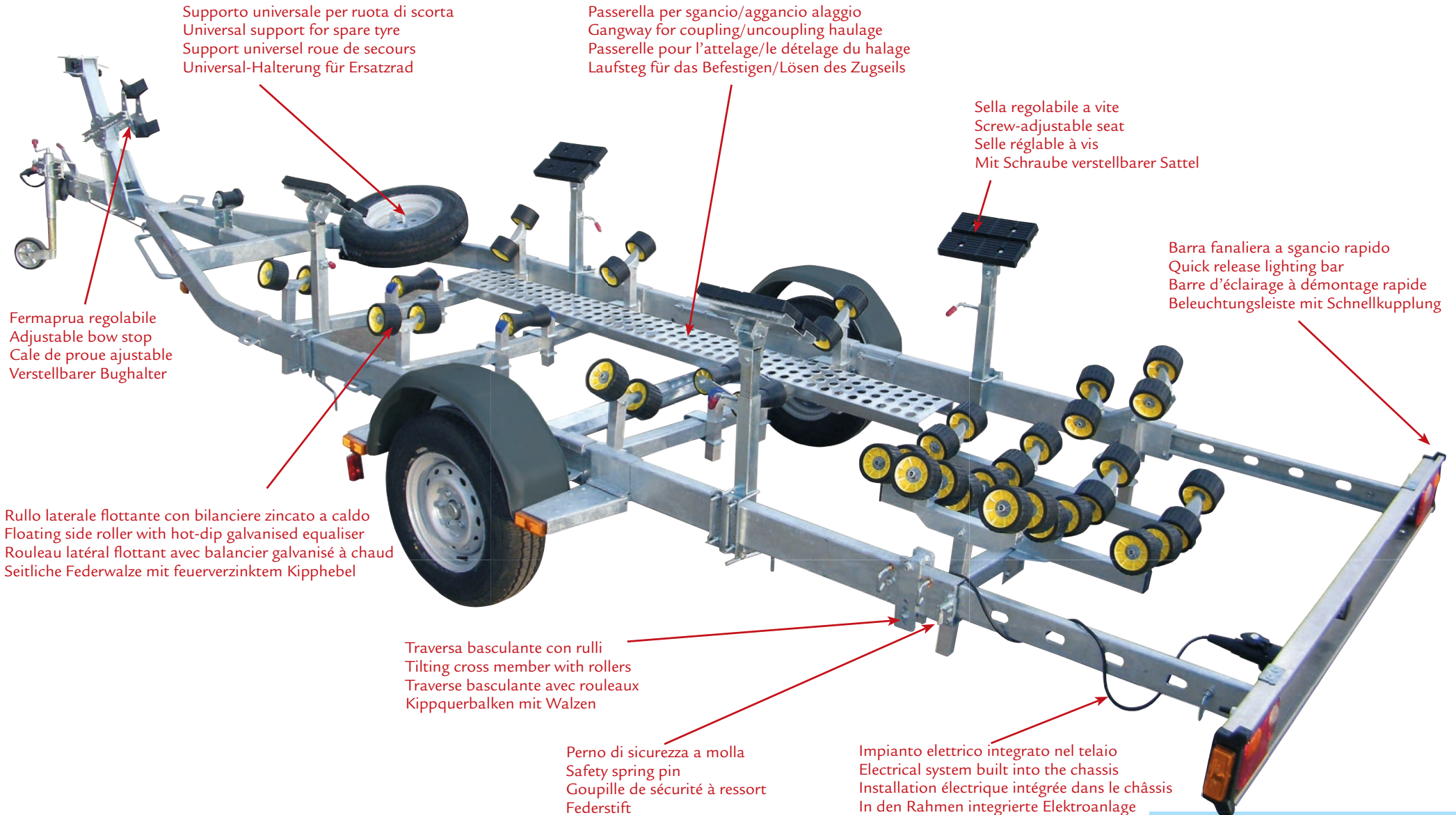



DOTAZIONE UNIVERSALE "VD" PER BARCHE A
VELA CON DERIVA
ADATTABILE DAL MODELLO N750...

UNIVERSAL "VD" EQUIPMENT FOR
SAILBOATS WITH DRIFT
CAN BE ADAPTED FROM MODEL N750...

ÉQUIPEMENT UNIVERSEL "VD" POUR
VOILIERS AVEC DÉRIVE
ADAPTABLE DEPUIS LE MODÈLE N750...

UNIVERSALZUBEHÖR „VD“ FÜR
SEGELBOOTE MIT KIELSCHWERT
ANPASSBAR VOM MODELL N750...



Peso attrezzatura
Equipment weight
Poids équipement
Gewicht der Ausrüstung
Kg 130



Colonna appoggio prua anteriore
Column supporting the front bow
Colonne d'appui de la proue avant
Stützsäule Bug



Colonna laterale registrabile
ed inclinabile
Adjustable, tilting side column
Colonne latérale réglable et inclinable
Verstellbare und kippbare seitliche Säule

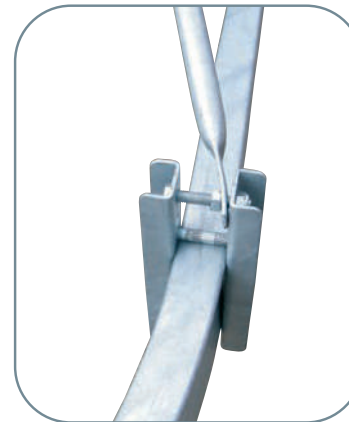

Ancoraggio tirante colonna
anteriore
Front column tie rod anchoring
Attelage tirant colonne avant
Vorgespannter Zuganker vordere Säule

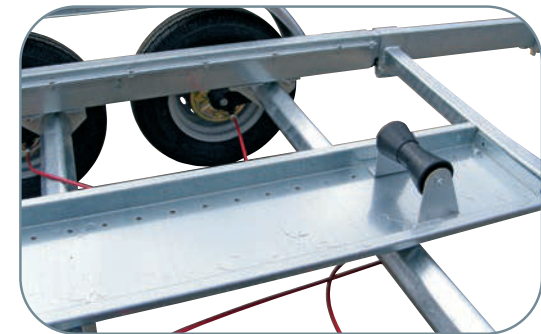

Appoggio deriva con battuta registrabile
Drift support with adjustable stop
Appui dérive avec butée ajustable
Auflage für Kielschwert mit verstellbarem
Anschlag

- R- Attrezzato con rulli, argano e fermaprua
- R- Equipped with rollers, winch and bow stop
- R- Equipé de rouleaux, treuil et cale de proue
- R- Ausgestattet mit walzen, winde und bughalter

- S- Attrezzato con selle laterali, argano e fermaprua
- S- Equipped with side seats, winch and bow stop
- S- Equipé de selles latérales, treuil et cale de proue
- S- Ausgestattet mit seitlichen sättern, winde und Bughalter

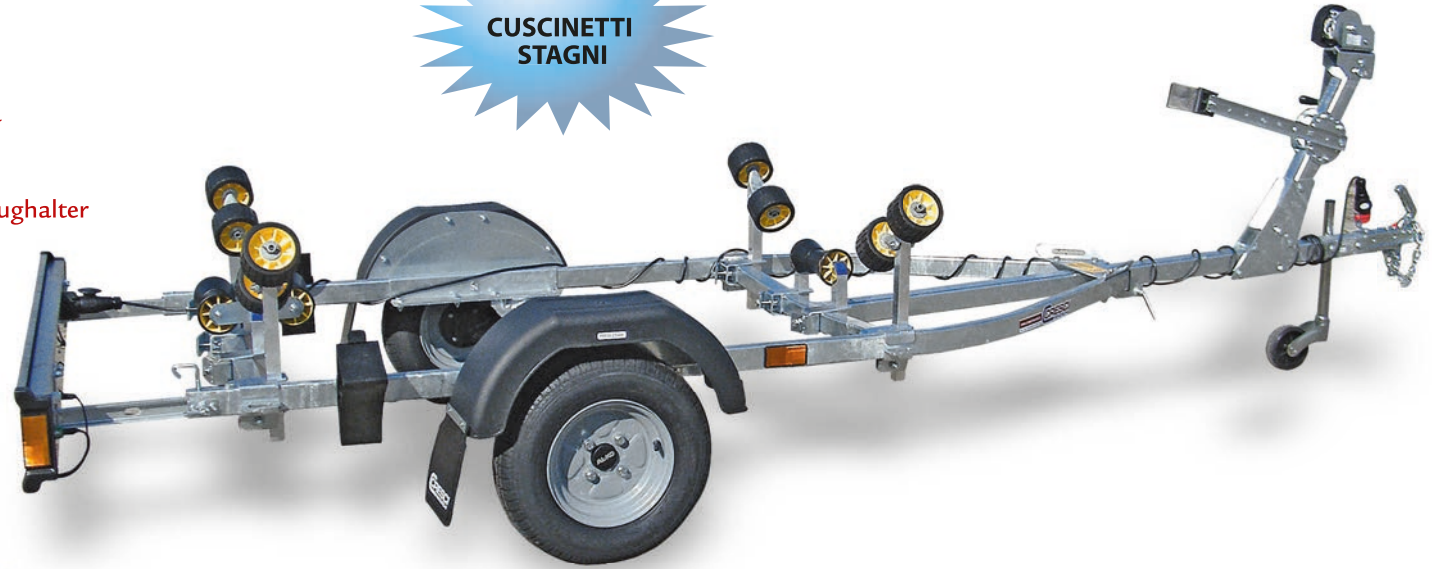

**SENZA FRENI
NO BRAKES
SANS FREINS
OHNE BREMSEN**

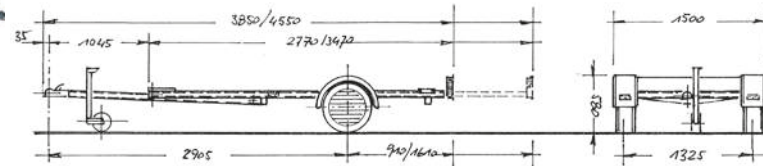

N6 MA-R-	600/400 Kg	485/285 Kg	450/250 Kg	455 - 395 cm	150 cm	5.00.10
N6 MA-S-	600/400 Kg	485/285 Kg	450/250 Kg	455 - 395 cm	150 cm	5.00.10
	Peso a pieno carico	Portata utile senza attrezzatura	Portata utile con attrezzatura standard	Lunghezza max e min.	Larghezza max	Ruote
	Full load weight	Capacity without equipment	Capacity with standard equipment	Max and min length	Width	Wheels
	Poids total en charge	Charge utile sans équipement	Charge utile avec équipement standard	Longueur max et min	Largeur max	Roues
	Zulässiges Gesamtgewicht	Nutzlast ohne Ausrüstung	Nutzlast mit Standardausrüstung	Min und Max. länge	Max. Breite	Räder

- TELAIO BASCULANTE
- TELAIO PROFILATO TUBOLARE DI GROSSO SPESSORE ZINCATO A CALDO
- PERNO A MOLLA DI SICUREZZA PER EVITARE FUORIUSCITA FANALERIA
- BARRA FANALERIA IN ALLUMINIO

- TILTING CHASSIS
- THICK, HOT-DIP GALVANIZED TUBULAR PROFILED CHASSIS
- SAFETY SPRING PIN TO PREVENT THE LIGHTING FROM COMING OUT
- ALUMINIUM LIGHTING BAR

- CHÂSSIS BASCULANT
- CHÂSSIS PROFILÉ TUBULAIRE DE GROSSE ÉPAISSEUR GALVANISÉ À CHAUD
- GOUPILLE DE SÉCURITÉ À RESSORT POUR ÉVITER LE GLISSEMENT DE LA Barre D'ÉCLAIRAGE
- BARRE D'ÉCLAIRAGE EN ALUMINIUM

- KIPPRAHMEN
- PROFILRAHMEN AUS STARKEN, FEUERVERZINKTEN ROHREN
- FEDERSTIFT ZUM SICHERN DER BELEUCHTUNG
- BELEUCHTUNGSLEISTE AUS ALUMINIUM

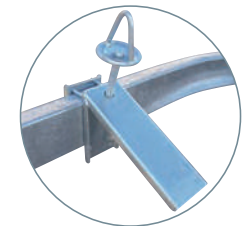

OPTIONAL

PER INFORMAZIONI E PREZZI POTETE CONSULTARE IL NOSTRO SITO INTERNET OPPURE RIVOLGERVI PRESSO UN RIVENDITORE DI ZONA. Per tutti i modelli la ruota di scorta è optional. Dati e misure del presente catalogo sono semplicemente indicativi e non impegnativi. La ditta si riserva qualsiasi modifica senza preavviso.



- R- Attrezzato con rulli, argano e fermaprua
- R- Equipped with rollers, winch and bow stop
- R- Equipé de rouleaux, treuil et cale de proue
- R- Ausgestattet mit walzen, winde und bughalter

New

CUSCINETTI STAGNI



**SENZA FRENI
NO BRAKES
SANS FREINS
OHNE BREMSEN**

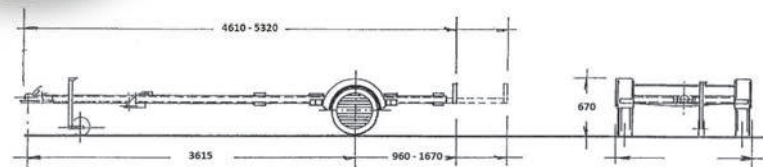

N4B S.F.-R-	750/600/400 Kg	610/460/260 Kg	575/425/225 Kg	532/461 cm	160 cm	155/70R13
	Peso a pieno carico	Portata utile senza attrezzatura	Portata utile con attrezzatura standard	Lunghezza max e min.	Larghezza max	Ruote
	Full load weight	Capacity without equipment	Capacity with standard equipment	Max and min length	Width	Wheels
	Poids total en charge	Charge utile sans équipement	Charge utile avec équipement standard	Longueur max et min	Largeur max	Roues
	Zulässiges Gesamtgewicht	Nutzlast ohne Ausrüstung	Nutzlast mit Standardausrüstung	Min und Max. länge	Max. Breite	Räder

- TELAIO BASCULANTE
- TELAIO PROFILATO TUBOLARE DI GROSSO SPESSORE ZINCATO A CALDO
- BARRA FANALERIA IN ALLUMINIO

- TILTING CHASSIS
- THICK, HOT-DIP GALVANIZED TUBULAR PROFILED CHASSIS
- ALUMINIUM LIGHTING BAR

- CHÂSSIS BASCULANT
- CHÂSSIS PROFILÉ TUBULAIRE DE GROSSE ÉPAISSEUR GALVANISÉ À CHAUD
- BARRE D'ÉCLAIRAGE EN ALUMINIUM

- KIPRAHMEN
- PROFILRAHMEN AUS STARKEN, FEUERVERZINKTEN ROHREN
- BELEUCHTUNGSLEISTE AUS ALUMINIUM

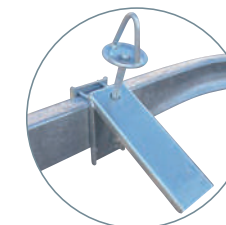

OPTIONAL

PER INFORMAZIONI E PREZZI POTETE CONSULTARE IL NOSTRO SITO INTERNET OPPURE RIVOLGERVI PRESSO UN RIVENDITORE DI ZONA. Per tutti i modelli la ruota di scorta è optional. Dati e misure del presente catalogo sono semplicemente indicativi e non impegnativi. La ditta si riserva qualsiasi modifica senza preavviso.

- R- Attrezzato con rulli, argano e fermaprua
- R- Equipped with rollers, winch and bow stop
- R- Equipé de rouleaux, treuil et cale de proue
- R- Ausgestattet mit walzen, winde und bughalter

SENZA FRENI
NO BRAKES
SANS FREINS
OHNE BREMSEN

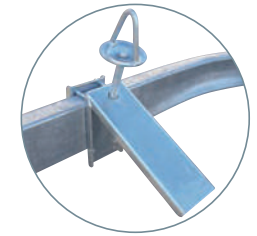

OPTIONAL



Traversa posteriore basculante di serie (multirullo)
Tilting rear cross member as standard (multi-roller)
Traverse arrière basculante de série (multi-rouleaux)
Serienmäßiger hinterer kipbarer querbalken (mehrere walzen)

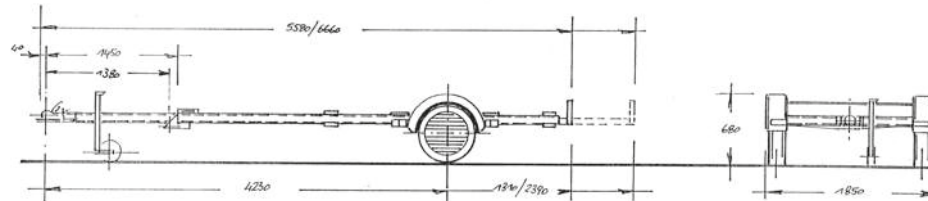

OPTIONAL

N750B S.F.-R-	750/600 Kg	555/405 Kg	515/365 Kg	666 - 558 cm	185 cm	155 R 13
	Peso a pieno carico Full load weight Poids total en charge Zulässiges Gesamtgewicht	Portata utile senza attrezzatura Capacity without equipment Charge utile sans équipement Nutzlast ohne Ausrüstung	Portata utile con attrezzatura standard Capacity with standard equipment Charge utile avec équipement standard Nutzlast mit Standardausrüstung	Lunghezza max e min. Max and min length Longueur max et min Min und Max. länge	Larghezza max Width Largeur max Max. Breite	Ruote Wheels Roues Räder

- TELAIO BASCULANTE
- TELAIO PROFILATO TUBOLARE DI GROSSO SPESSORE ZINCATO A CALDO
- SUPPORTI PARAFANGHI CALPESTABILI
- BARRA FANALERIA IN ALLUMINIO / A SMONTAGGIO RAPIDO
- PERNO A MOLLA DI SICUREZZA PER EVITARE FUORIUSCITA FANALERIA
- RUOTINO DI STAZIONAMENTO ZINCATO A CALDO CON CUSCINETTO PER MINIMO SFORZO IN ALZATA

- TILTING CHASSIS
- THICK, HOT-DIP GALVANIZED TUBULAR PROFILED CHASSIS
- WALK-ON MUD GUARD SUPPORTS
- ALUMINIUM LIGHTING BAR / QUICK TO DISASSEMBLE
- SAFETY SPRING PIN TO PREVENT THE LIGHTING FROM COMING OUT
- HOT-DIP GALVANISED PARKING BRAKE WITH BEARING FOR MINIMAL STRAIN

- CHÂSSIS BASCULANT
- CHÂSSIS PROFILÉ TUBULAIRE DE GROSSE ÉPAISSEUR GALVANISÉ À CHAUD
- SUPPORTS GARDE-BOUE CIRCULABLES
- BARRÉ D'ÉCLAIRAGE EN ALUMINIUM / À DÉMONTAGE RAPIDE
- GOUPILLE DE SÉCURITÉ À RESSORT POUR ÉVITER LE GLISSEMENT DE LA BARRE D'ÉCLAIRAGE
- ROUE JOCKEY DE STATIONNEMENT GALVANISÉE À CHAUD AVEC COUSSINET POUR UN EFFORT MINIMUM EN LEVÉE

- KIPPRAHMEN
- PROFILRAHMEN AUS STARKEN, FEUERVERZINKTEN ROHREN
- BEGEBHARE KOTFLÜGELHALTERUNGEN
- BELEUCHTUNGSLEISTE AUS ALUMINIUM / SCHNELL ABBAUBAR
- FEDERSTIFT ZUM SICHERN DER BELEUCHTUNG
- FEUERVERZINKTES FESTSTELLRAD MIT LAGER FÜR MINIMALE ANSTRENGUNG BEIM ANHEBEN

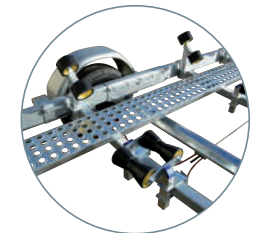

OPTIONAL

PER INFORMAZIONI E PREZZI POTETE CONSULTARE IL NOSTRO SITO INTERNET OPPURE RIVOLGERVI PRESSO UN RIVENDITORE DI ZONA. Per tutti i modelli la ruota di scorta è optional. Dati e misure del presente catalogo sono semplicemente indicativi e non impegnativi. La ditta si riserva qualsiasi modifica senza preavviso.



- R- Attrezzato con rulli, argano e fermaprua
- R- Equipped with rollers, winch and bow stop
- R- Equipé de rouleaux, treuil et cale de proue
- R- Ausgestattet mit walzen, winde und bughalter

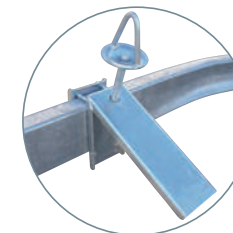

OPTIONAL



- Traversa posteriore basculante di serie (multirullo)
- Tilting rear cross member as standard (multi-roller)
- Traverse arrière basculante de série (multi-rouleaux)
- Serienmäßiger hinterer kipbarer querbalken (mehrere walzen)

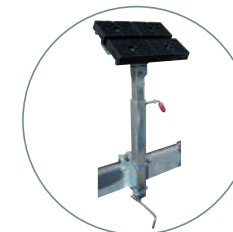
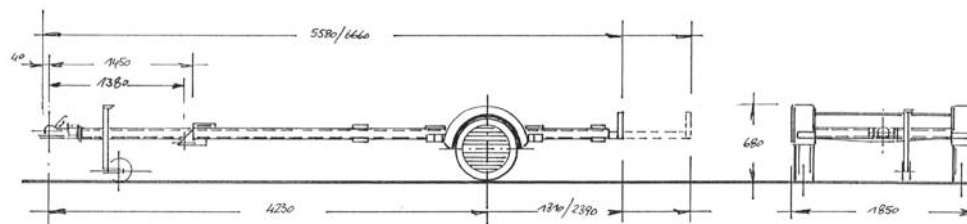

OPTIONAL

N750BC-R-	750/600 Kg	530/380 Kg	490 /340 Kg	666 - 558 cm	185 cm	155 R 13
	Peso a pieno carico	Portata utile senza attrezzatura	Portata utile con attrezzatura standard	Lunghezza max e min.	Larghezza max	Ruote
	Full load weight	Capacity without equipment	Capacity with standard equipment	Max and min length	Width	Wheels
	Poids total en charge	Charge utile sans équipement	Charge utile avec équipement standard	Longueur max et min	Largeur max	Roues
	Zulässiges Gesamtgewicht	Nutzlast ohne Ausrüstung	Nutzlast mit Standardausrüstung	Min und Max. länge	Max. Breite	Räder

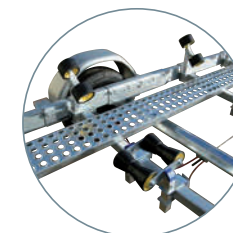

OPTIONAL

- TELAIO BASCULANTE
- TELAIO PROFILATO TUBOLARE DI GROSSO SPESSORE ZINCATO A CALDO
- SUPPORTI PARAFANGHI CALPESTABILI
- BARRA FANALERIA IN ALLUMINIO / A SMONTAGGIO RAPIDO
- PERNO A MOLLA DI SICUREZZA PER EVITARE FUORIUSCITA FANALERIA
- IMPIANTO ELETTRICO PARZIALMENTE INTERNO AL TELAIO
- RUOTINO DI STAZIONAMENTO ZINCATO A CALDO CON CUSCINETTO PER MINIMO SFORZO IN ALZATA

- TILTING CHASSIS
- THICK, HOT-DIP GALVANIZED TUBULAR PROFILED CHASSIS
- WALK-ON MUD GUARD SUPPORTS
- ALUMINIUM LIGHTING BAR / QUICK TO DISASSEMBLE
- SAFETY SPRING PIN TO PREVENT THE LIGHTING FROM COMING OUT
- ELECTRICAL SYSTEM PARTLY INSIDE THE CHASSIS
- HOT-DIP GALVANISED PARKING BRAKE WITH BEARING FOR MINIMAL STRAIN

- CHÂSSIS BASCULANT
- CHÂSSIS PROFILÉ TUBULAIRE DE GROSSE ÉPAISSEUR GALVANISÉ À CHAUD
- SUPPORTS GARDE-BOUE CIRCULABLES
- BARRE D'ÉCLAIRAGE EN ALUMINIUM / À DÉMONTAGE RAPIDE
- GOUPILLE DE SÉCURITÉ À RESSORT POUR ÉVITER LE GLISSEMENT DE LA BARRE D'ÉCLAIRAGE
- INSTALLATION ÉLECTRIQUE PARTIELLEMENT INTÉGRÉE AU CHÂSSIS
- ROUE JOCKEY DE STATIONNEMENT GALVANISÉE À CHAUD AVEC COUSSINET POUR UN EFFORT MINIMUM EN LEVÉE

- KIPRAHMEN
- PROFILRAHMEN AUS STARKEN, FEUERVERZINKTEN ROHREN
- BEGEBBARE KOTFLÜGELHALTERUNGEN
- BELEUCHTUNGSLEISTE AUS ALUMINIUM / SCHNELL ABBAUBAR
- FEDERSTIFT ZUM SICHERN DER BELEUCHTUNG
- ELEKTROANLAGE ZUM TEIL IN DEN RAHMEN INTEGRIERT
- FEUERVERZINKTES FESTSTELLRAD MIT LAGER FÜR MINIMALE ANSTRENGUNG BEIM ANHEBEN

PER INFORMAZIONI E PREZZI POTETE CONSULTARE IL NOSTRO SITO INTERNET OPPURE RIVOLGERVI PRESSO UN RIVENDITORE DI ZONA. Per tutti i modelli la ruota di scorta è optional. Dati e misure del presente catalogo sono semplicemente indicativi e non impegnativi. La ditta si riserva qualsiasi modifica senza preavviso.

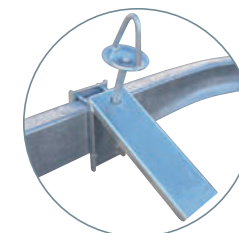
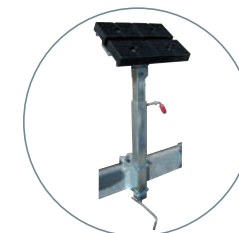
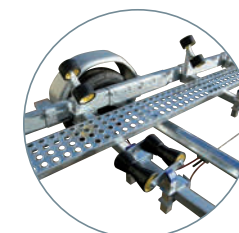
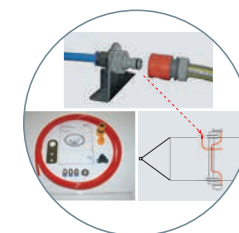

- R- Attrezzato con rulli, argano e fermaprua
- R- Equipped with rollers, winch and bow stop
- R- Equipé de rouleaux, treuil et cale de proue
- R- Ausgestattet mit walzen, winde und bughalter

OPTIONAL

OPTIONAL

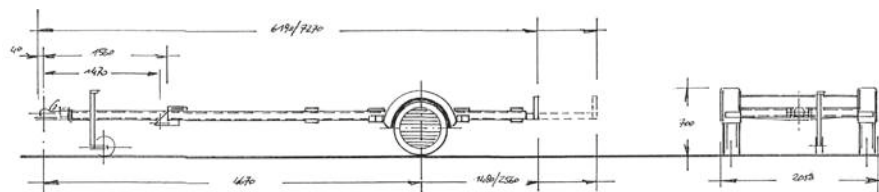
OPTIONAL

OPTIONAL

Traversa posteriore basculante di serie (multirullo)
Tilting rear cross member as standard (multi-roller)
Traverse arrière basculante de série (multi-rouleaux)
Serienmäßiger hinterer kipbarer querbalken (mehrere walzen)



N750B-R-	750 Kg	490 Kg	415 Kg	727 - 619 cm	205 cm	155 R 13
N1000B-R-	1000 Kg	740 Kg	665 Kg	727 - 619 cm	205 cm	155 R 13
	Peso a pieno carico	Portata utile senza attrezzatura	Portata utile con attrezzatura standard	Lunghezza max e min	Larghezza max	Ruote
	Full load weight	Capacity without equipment	Capacity with standard equipment	Max and min length	Width	Wheels
	Poids total en charge	Charge utile sans équipement	Charge utile avec équipement standard	Longueur max et min	Largeur max	Roues
	Zulässiges Gesamtgewicht	Nutzlast ohne Ausrüstung	Nutzlast mit Standardausrüstung	Min und Max. länge	Max. Breite	Räder

- TELAIO BASCULANTE
- TELAIO PROFILATO TUBOLARE DI GROSSO SPESSORE ZINCATO A CALDO
- SUPPORTI PARAFANGHI CALPESTABILI
- BARRA FANALERIA IN ALLUMINIO / A SMONTAGGIO RAPIDO
- PERNO A MOLLA DI SICUREZZA PER EVITARE FUORIUSCITA FANALERIA
- IMPIANTO ELETTRICO PARZIALMENTE INTERNO AL TELAIO
- RUOTINO DI STAZIONAMENTO ZINCATO A CALDO CON CUSCINETTO PER MINIMO SFORZO IN ALZATA

- TILTING CHASSIS
- THICK, HOT-DIP GALVANIZED TUBULAR PROFILED CHASSIS
- WALK-ON MUD GUARD SUPPORTS
- ALUMINIUM LIGHTING BAR / QUICK TO DISASSEMBLE
- SAFETY SPRING PIN TO PREVENT THE LIGHTING FROM COMING OUT
- ELECTRICAL SYSTEM PARTLY INSIDE THE CHASSIS
- HOT-DIP GALVANISED PARKING BRAKE WITH BEARING FOR MINIMAL STRAIN

- CHÂSSIS BASCULANT
- CHÂSSIS PROFILÉ TUBULAIRE DE GROSSE ÉPAISSEUR GALVANISÉ A CHAUD
- SUPPORTS GARDE-BOUE CIRCULABLES
- BARRE D'ÉCLAIRAGE EN ALUMINIUM / À DÉMONTAGE RAPIDE
- GOUPILLE DE SÉCURITÉ À RESSORT POUR ÉVITER LE GLISSEMENT DE LA Barre D'ÉCLAIRAGE
- INSTALLATION ÉLECTRIQUE PARTIELLEMENT INTÉGRÉE AU CHÂSSIS
- ROUE JOCKEY DE STATIONNEMENT GALVANISÉE À CHAUD AVEC COUSSINET POUR UN EFFORT MINIMUM EN LEVÉ

- KIPPRAHMEN
- PROFILRAHMEN AUS STARKEN, FEUERVERZINKTEN ROHREN
- BEGEBBARE KOTFLÜGELHALTERUNGEN
- BELEUCHTUNGSLEISTE AUS ALUMINIUM / SCHNELL ABBAUBAR
- FEDERSTIFT ZUM SICHERN DER BELEUCHTUNG
- ELEKTROANLAGE ZUM TEIL IN DEN RAHMEN INTEGRIERT
- FEUERVERZINKTES FESTSTELLRAD MIT LAGER FÜR MINIMALE ANSTRENGUNG BEIM ANHEBEN

PER INFORMAZIONI E PREZZI POTETE CONSULTARE IL NOSTRO SITO INTERNET OPPURE RIVOLGERVI PRESSO UN RIVENDITORE DI ZONA. Per tutti i modelli la ruota di scorta è optional. Dati e misure del presente catalogo sono semplicemente indicativi e non impegnativi. La ditta si riserva qualsiasi modifica senza preavviso.

- R- Attrezzato con rulli, argano e fermaprua
- R- Equipped with rollers, winch and bow stop
- R- Equipé de rouleaux, treuil et cale de proue
- R- Ausgestattet mit walzen, winde und bughalter

**CUSCINETTI
STAGNI
GUAINE FRENO
IN INOX**

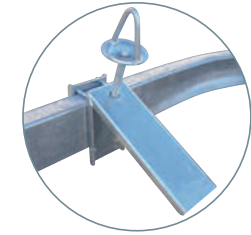

OPTIONAL



OPTIONAL

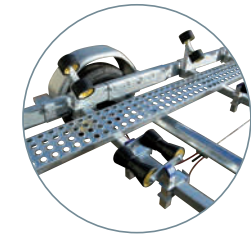

OPTIONAL

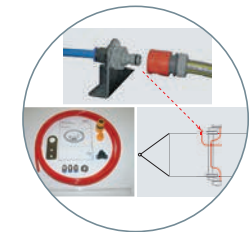

OPTIONAL

Traversa posteriore basculante di serie (multirullo)
Tilting rear cross member as standard (multi-roller)
Traverse arrière basculante de série (multi-rouleaux)
Serienmäßiger hinterer kipparer querbalken (mehrere walzen)

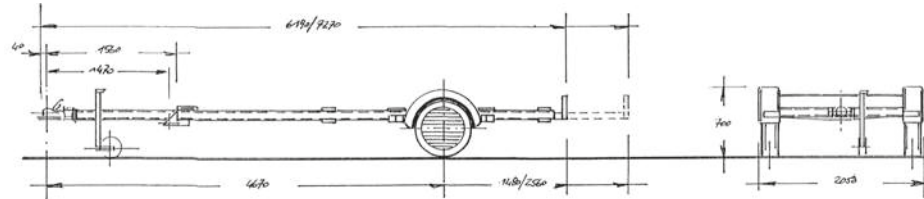

N1350B-R-	1350/1200/1100 Kg	1055/905/805 Kg	980/830/730 Kg	727 - 619 cm	205 cm	165 R 13C
	Peso a pieno carico	Portata utile senza attrezzatura	Portata utile con attrezzatura standard	Lunghezza max e min.	Larghezza max	Ruote
	Full load weight	Capacity without equipment	Capacity with standard equipment	Max and min length	Width	Wheels
	Poids total en charge	Charge utile sans équipement	Charge utile avec équipement standard	Longueur max et min	Largeur max	Roues
	Zulässiges Gesamtgewicht	Nutzlast ohne Ausrüstung	Nutzlast mit Standardausrüstung	Min und Max. länge	Max. Breite	Räder

- TELAIO BASCULANTE
- TELAIO PROFILATO TUBOLARE DI GROSSO SPESSORE ZINCATO A CALDO
- SUPPORTI PARAFANGHI CALPESTABILI
- BARRA FANALERIA IN ALLUMINIO / A SMONTAGGIO RAPIDO
- PERNO A MOLLA DI SICUREZZA PER EVITARE FUORIUSCITA FANALERIA
- IMPIANTO ELETTRICO PARZIALMENTE INTERNO AL TELAIO
- RUOTINO DI STAZIONAMENTO ZINCATO A CALDO CON CUSCINETTO PER MINIMO SFORZO IN ALZATA

- TILTING CHASSIS
- THICK, HOT-DIP GALVANIZED TUBULAR PROFILED CHASSIS
- WALK-ON MUD GUARD SUPPORTS
- ALUMINIUM LIGHTING BAR / QUICK TO DISASSEMBLE
- SAFETY SPRING PIN TO PREVENT THE LIGHTING FROM COMING OUT
- ELECTRICAL SYSTEM PARTLY INSIDE THE CHASSIS
- HOT-DIP GALVANISED PARKING BRAKE WITH BEARING FOR MINIMAL STRAIN

- CHÂSSIS BASCULANT
- CHÂSSIS PROFILÉ TUBULAIRE DE GROSSE ÉPAISSEUR GALVANISÉ À CHAUD
- SUPPORTS GARDE-BOUE CIRCULABLES
- BARRE D'ÉCLAIRAGE EN ALUMINIUM / À DÉMONTAGE RAPIDE
- GOUPILLE DE SÉCURITÉ À RESSORT POUR ÉVITER LE GLISSEMENT DE LA BARRE D'ÉCLAIRAGE
- INSTALLATION ÉLECTRIQUE PARTIELLEMENT INTÉGRÉE AU CHÂSSIS
- ROUE JOCKEY DE STATIONNEMENT GALVANISÉE À CHAUD AVEC COUSSINET POUR UN EFFORT MINIMUM EN LÈVÉ

- KIPRAHMEN
- PROFILRAHMEN AUS STARKEN, FEUERVERZINKTEN ROHREN
- BEGEBHARE KOTFLÜGELHALTERUNGEN
- BELEUCHTUNGSLEISTE AUS ALUMINIUM / SCHNELL ABBAUBAR
- FEDERSTIFT ZUM SICHERN DER BELEUCHTUNG INTEGRIERT
- FEUERVERZINKTES FESTSTELLRAD MIT LAGER FÜR MINIMALE ANSTRENGUNG BEIM ANHEBEN

PER INFORMAZIONI E PREZZI POTETE CONSULTARE IL NOSTRO SITO INTERNET OPPURE RIVOLGERVI PRESSO UN RIVENDITORE DI ZONA. Per tutti i modelli la ruota di scorta è optional. Dati e misure del presente catalogo sono semplicemente indicativi e non impegnativi. La ditta si riserva qualsiasi modifica senza preavviso.

- R- Attrezzato con rulli, argano e fermaprua
- R- Equipped with rollers, winch and bow stop
- R- Equipé de rouleaux, treuil et cale de proue
- R- Ausgestattet mit walzen, winde und bughalter

**CUSCINETTI
STAGNI
GUAINE FRENO
IN INOX**

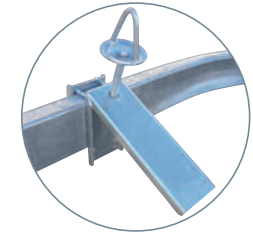
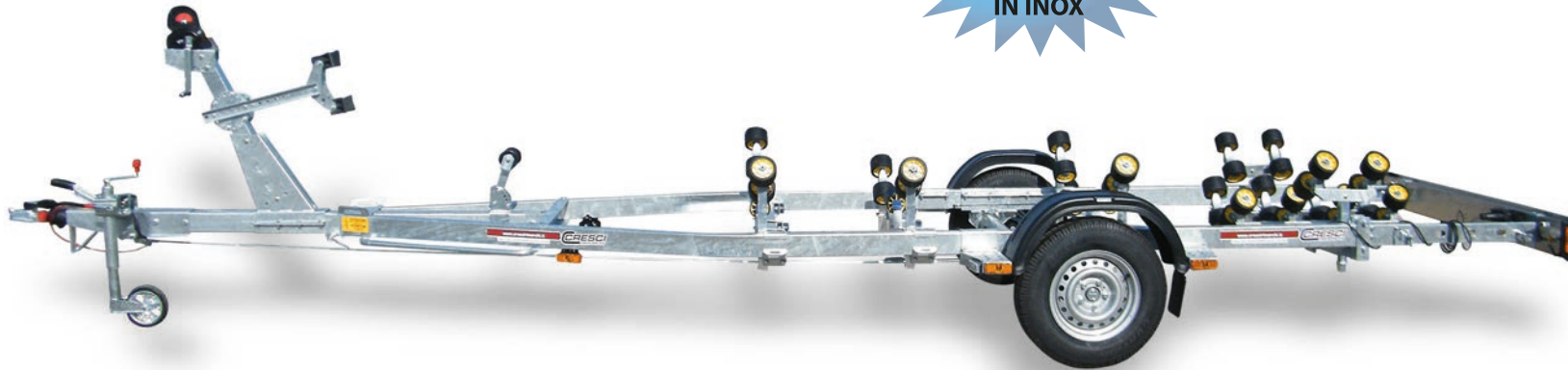

OPTIONAL



OPTIONAL

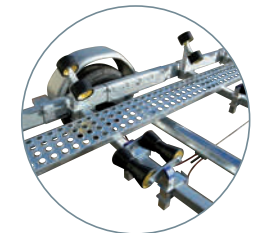

OPTIONAL

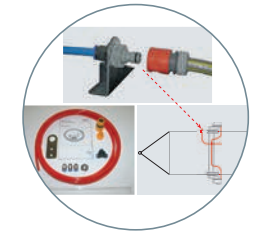

OPTIONAL

Traversa posteriore basculante di serie (multirullo)
Tilting rear cross member as standard (multi-roller)
Traverse arrière basculante de série (multi-rouleaux)
Serienmäßiger hinterer kipbarer Querbalken (mehrere walzen)

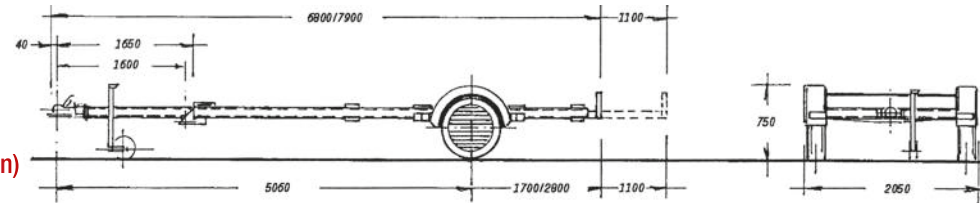

N1500BC-R-	1500/1300/1000 Kg	1170/970/670 Kg	1070/870/570 Kg	790 - 680 cm	205 cm	185 R 14C
	Peso a pieno carico Full load weight Poids total en charge Zulässiges Gesamtgewicht	Portata utile senza attrezzatura Capacity without equipment Charge utile sans équipement Nutzlast ohne Ausrüstung	Portata utile con attrezzatura standard Capacity with standard equipment Charge utile avec équipement standard Nutzlast mit Standardausrüstung	Lunghezza max e min. Max and min length Longueur max et min Min und Max. länge	Larghezza max Width Largeur max Max. Breite	Ruote Wheels Roues Räder

- TELAIO BASCULANTE
- TELAIO PROFILATO TUBOLARE DI GROSSO SPESSORE ZINCATO A CALDO
- SUPPORTI PARAFANGHI CALPESTABILI
- BARRA FANALERIA IN ALLUMINIO / A SMONTAGGIO RAPIDO
- PERNO A MOLLA DI SICUREZZA PER EVITARE FUORIUSCITA FANALERIA
- IMPIANTO ELETTRICO PARZIALMENTE INTERNO AL TELAIO
- RUOTINO DI STAZIONAMENTO ZINCATO A CALDO CON CUSCINETTO PER MINIMO SFORZO IN ALZATA

- TILTING CHASSIS
- THICK, HOT-DIP GALVANIZED TUBULAR PROFILED CHASSIS
- WALK-ON MUD GUARD SUPPORTS
- ALUMINIUM LIGHTING BAR / QUICK TO DISASSEMBLE
- SAFETY SPRING PIN TO PREVENT THE LIGHTING FROM COMING OUT
- ELECTRICAL SYSTEM PARTLY INSIDE THE CHASSIS
- HOT-DIP GALVANIZED PARKING BRAKE WITH BEARING FOR MINIMAL STRAIN

- CHÂSSIS BASCULANT
- CHÂSSIS PROFILÉ TUBULAIRE DE GROSSE ÉPAISSEUR GALVANISÉ A CHAUD
- SUPPORTS GARDE-BOUE CIRCULABLES
- RAMPE D'ÉCLAIRAGE EN ALUMINIUM / À DÉMONTAGE RAPIDE
- GOUPILLE DE SÉCURITÉ À RESSORT POUR ÉVITER LE GLISSEMENT DE LA RAMPE D'ÉCLAIRAGE
- INSTALLATION ÉLECTRIQUE PARTIELLEMENT INTÉGRÉE AU CHÂSSIS
- ROUE JOCKEY DE STATIONNEMENT GALVANISÉE À CHAUD AVEC COUSSINET POUR UN EFFORT MINIMUM EN LEVÉE

- KIPPRAHMEN
- PROFILRAHMEN AUS STARKEN, FEUERVERZINKTEN ROHREN
- BEGEBBARE KOTFLÜGELHALTERUNGEN
- BELEUCHTUNGSLEISTE AUS ALUMINIUM / SCHNELL ABBAUBAR
- FEDERSTIFT ZUM SICHERN DER BELEUCHTUNG
- ELEKTROANLAGE ZUM TEIL IN DEN RAHMEN INTEGRIERT
- FEUERVERZINKTES FESTSTELLRAD MIT LAGER FÜR MINIMALE ANSTRENGUNG BEIM ANHEBEN

PER INFORMAZIONI E PREZZI POTETE CONSULTARE IL NOSTRO SITO INTERNET OPPURE RIVOLGERVI PRESSO UN RIVENDITORE DI ZONA. Per tutti i modelli la ruota di scorta è optional. Dati e misure del presente catalogo sono semplicemente indicativi e non impegnativi. La ditta si riserva qualsiasi modifica senza preavviso.



RIMORCHI TRASPORTO IMBARCAZIONI

- R- Attrezzato con rulli, argano e fermaprua
- R- Equipped with rollers, winch and bow stop
- R- Equipé de rouleaux, treuil et cale de proue
- R- Ausgestattet mit walzen, winde und bughalter

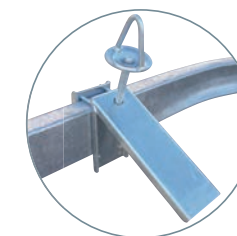

OPTIONAL

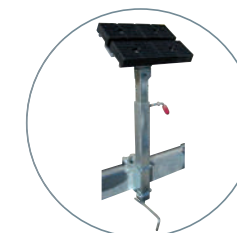

OPTIONAL

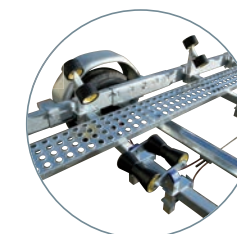

OPTIONAL

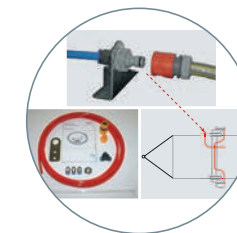

OPTIONAL

Traversa posteriore basculante di serie (multirullo)
Tilting rear cross member as standard (multi-roller)
Traverse arrière basculante de série (multi-rouleaux)
Serienmäßiger hinterer kipbarer querbalken (mehrere walzen)

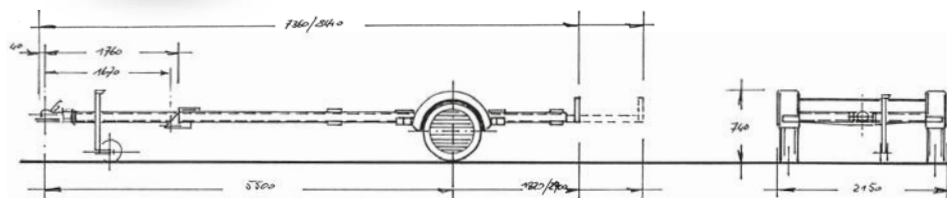

N1800BC-R-	1800 Kg	1400 Kg	1300 Kg	844 - 736 cm	215 cm	185 R 14C
N1500B-R-	1500/1300/1000 Kg	1120/920/620 Kg	1020/820/520 Kg	844 - 736 cm	215 cm	185 R 14C
	Peso a pieno carico	Portata utile senza attrezzatura	Portata utile con attrezzatura standard	Lunghezza max e min.	Larghezza max	Ruote
	Full load weight	Capacity without equipment	Capacity with standard equipment	Max and min lenght	Width	Wheels
	Poids total en charge	Charge utile sans équipement	Charge utile avec équipement standard	Longueur max et min	Largueur max	Roues
	Zulässiges Gesamtgewicht	Nutzlast ohne Ausrüstung	Nutzlast mit Standardausrüstung	Min und Max. länge	Max. Breite	Räder

- TELAIO BASCULANTE
- TELAIO PROFILATO TUBOLARE DI GROSSO SPESSORE ZINCATO A CALDO
- SUPPORTI PARAFANGHI CALPESTABILI
- BARRA FANALERIA IN ALLUMINIO / A SMONTAGGIO RAPIDO
- PERNO A MOLLA DI SICUREZZA PER EVITARE FUORIUSCITA FANALERIA
- IMPIANTO ELETTRICO PARZIALMENTE INTERNO AL TELAIO
- RUOTINO DI STAZIONAMENTO ZINCATO A CALDO CON CUSCINETTO PER MINIMO SFORZO IN ALZATA

- TILTING CHASSIS
- THICK, HOT-DIP GALVANIZED TUBULAR PROFILED CHASSIS
- WALK-ON MUD GUARD SUPPORTS
- ALUMINIUM LIGHTING BAR / QUICK TO DISASSEMBLE
- SAFETY SPRING PIN TO PREVENT THE LIGHTING FROM COMING OUT
- ELECTRICAL SYSTEM PARTLY INSIDE THE CHASSIS
- HOT-DIP GALVANISED PARKING BRAKE WITH BEARING FOR MINIMAL STRAIN

- CHÂSSIS BASCULANT
- CHÂSSIS PROFILÉ TUBULAIRE DE GROSSE ÉPAISSEUR GALVANISÉ À CHAUD
- SUPPORTS GARDE-BOUE CIRCULABLES
- RAMPE D'ÉCLAIRAGE EN ALUMINIUM / À DÉMONTAGE RAPIDE
- GOUPILLE DE SÉCURITÉ À RESSORT POUR ÉVITER LE GLISSEMENT DE LA RAMPE D'ÉCLAIRAGE
- INSTALLATION ÉLECTRIQUE PARTIELLEMENT INTÉGRÉE AU CHÂSSIS
- ROUE JOCKEY DE STATIONNEMENT GALVANISÉE À CHAUD AVEC COUSSINET POUR UN EFFORT MINIMUM EN LEVÉE

- KIPRAHMEN
- PROFILRAHMEN AUS STARKEN, FEUERVERZINKTEN ROHREN
- BEGEBHARE KOTFLÜGELHALTERUNGEN
- BELEUCHTUNGSLEISTE AUS ALUMINIUM / SCHNELL ABBAUBAR
- FEDERSTIFT ZUM SICHERN DER BELEUCHTUNG
- ELEKTROANLAGE ZUM TEIL IN DEN RAHMEN INTEGRIERT
- FEUERVERZINKTES FESTSTELLRAD MIT LAGER FÜR MINIMALE ANSTRENGUNG BEIM ANHEBEN

PER INFORMAZIONI E PREZZI POTETE CONSULTARE IL NOSTRO SITO INTERNET OPPURE RIVOLGERVI PRESSO UN RIVENDITORE DI ZONA. Per tutti i modelli la ruota di scorta è optional. Dati e misure del presente catalogo sono semplicemente indicativi e non impegnativi. La ditta si riserva qualsiasi modifica senza preavviso.

- R- Attrezzato con rulli, argano e fermaprua
- R- Equipped with rollers, winch and bow stop
- R- Equipé de rouleaux, treuil et cale de proue
- R- Ausgestattet mit walzen, winde und bughalter

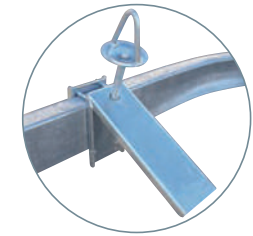

OPTIONAL



OPTIONAL

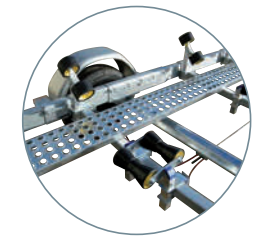

OPTIONAL

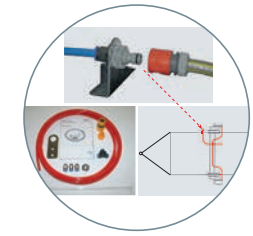

OPTIONAL

Traversa posteriore basculante di serie (multirullo)
Tilting rear cross member as standard (multi-roller)
Traverse arrière basculante de série (multi-rouleaux)
Serienmäßiger hinterer kipbarer querbalken (mehrere walzen)

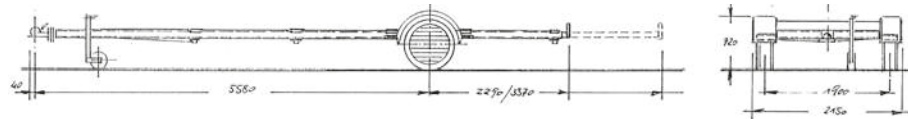

N1800-R-	1800/1500 Kg	1340/1040 Kg	1255/955 Kg	899 - 791 cm	215 cm	195 R 14C
	Peso a pieno carico	Portata utile senza attrezzatura	Portata utile con attrezzatura standard	Lunghezza max e min	Larghezza max	Ruote
	Full load weight	Capacity without equipment	Capacity with standard equipment	Max and min length	Width	Wheels
	Poids total en charge	Charge utile sans équipement	Charge utile avec équipement standard	Longueur max et min	Largeur max	Roues
	Zulässiges Gesamtgewicht	Nutzlast ohne Ausrüstung	Nutzlast mit Standardausrüstung	Min und Max. länge	Max. Breite	Räder

- TELAIO PROFILATO TUBOLARE DI GROSSO SPESSORE ZINCATO A CALDO
- SUPPORTI PARAFANGHI CALPESTABILI
- BARRA FANALERIA IN ALLUMINIO / A SMONTAGGIO RAPIDO
- PERNO A MOLLA DI SICUREZZA PER EVITARE FUORIUSCITA FANALERIA
- IMPIANTO ELETTRICO PARZIALMENTE INTERNO AL TELAIO
- RUOTINO DI STAZIONAMENTO ZINCATO A CALDO CON CUSCINETTO PER MINIMO SFORZO IN ALZATA

- THICK, HOT-DIP GALVANIZED TUBULAR PROFILED CHASSIS
- WALK-ON MUD GUARD SUPPORTS
- ALUMINIUM LIGHTING BAR / QUICK TO DISASSEMBLE
- SAFETY SPRING PIN TO PREVENT THE LIGHTING FROM COMING OUT
- ELECTRICAL SYSTEM PARTLY INSIDE THE CHASSIS
- HOT-DIP GALVANISED PARKING BRAKE WITH BEARING FOR MINIMAL STRAIN

- CHÂSSIS PROFILÉ TUBULAIRE DE GROSSE ÉPAISSEUR GALVANISÉ À CHAUD
- SUPPORTS GARDE-BOUE CIRCULABLES
- BARRE D'ÉCLAIRAGE EN ALUMINIUM / À DÉMONTAGE RAPIDE
- GOUPILLE DE SÉCURITÉ À RESSORT POUR ÉVITER LE GLISSEMENT DE LA Barre D'ÉCLAIRAGE
- INSTALLATION ÉLECTRIQUE PARTIELLEMENT INTÉGRÉE AU CHÂSSIS
- ROUE JOCKEY DE STATIONNEMENT GALVANISÉE À CHAUD AVEC COUSSINET POUR UN EFFORT MINIMUM EN LÉVÉ

- PROFILRAHMEN AUS STARKEN, FEUERVERZINKTEN ROHREN
- BEGEBHARE KOTFLÜGELHALTERUNGEN
- BELEUCHTUNGSLEISTE AUS ALUMINIUM / SCHNELL ABBAUBAR
- FEDERSTIFT ZUM SICHERN DER BELEUCHTUNG
- ELEKTROANLAGE ZUM TEIL IN DEN RAHMEN INTEGRIERT
- FEUERVERZINKTES FESTSTELLRAD MIT LAGER FÜR MINIMALE ANSTRENGUNG BEIM ANHEBEN

PER INFORMAZIONI E PREZZI POTETE CONSULTARE IL NOSTRO SITO INTERNET OPPURE RIVOLGERVI PRESSO UN RIVENDITORE DI ZONA. Per tutti i modelli la ruota di scorta è optional. Dati e misure del presente catalogo sono semplicemente indicativi e non impegnativi. La ditta si riserva qualsiasi modifica senza preavviso.

- R- Attrezzato con rulli, argano e fermaprua
- R- Equipped with rollers, winch and bow stop
- R- Equipé de rouleaux, treuil et cale de proue
- R- Ausgestattet mit walzen, winde und bughalter

**CUSCINETTI
STAGNI
GUAINE FRENO
IN INOX**

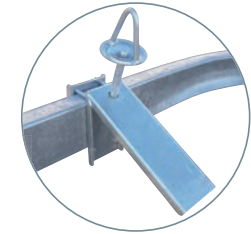

OPTIONAL



OPTIONAL

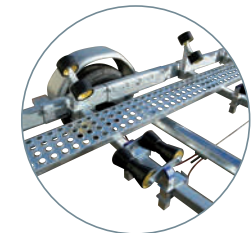

OPTIONAL

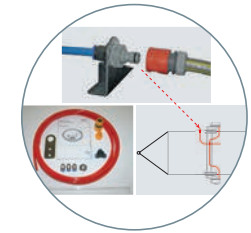

OPTIONAL

Traversa posteriore basculante di serie (multirullo)
Tilting rear cross member as standard (multi-roller)
Traverse arrière basculante de série (multi-rouleaux)
Serienmäßiger hinterer kipparer querbalken (mehrere walzen)

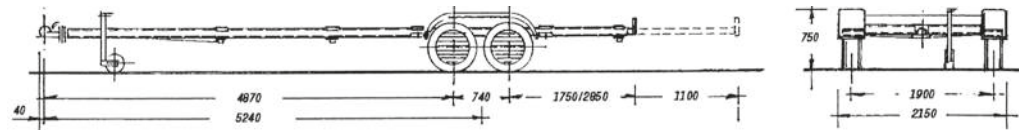

N2300-R-	2300/2000/1800/1600 Kg	1820/1520/1320/1120 Kg	1720/1420/1220/1020 Kg	850 - 740 cm	215 cm	185 R 14C
	Peso a pieno carico	Portata utile senza attrezzatura	Portata utile con attrezzatura standard	Lunghezza max e min.	Larghezza max	Ruote
	Full load weight	Capacity without equipment	Capacity with standard equipment	Max and min length	Width	Wheels
	Poids total en charge	Charge utile sans équipement	Charge utile avec équipement standard	Longueur max et min	Largueur max	Roues
	Zulässiges Gesamtgewicht	Nutzlast ohne Ausrüstung	Nutzlast mit Standardausrüstung	Min und Max. länge	Max. Breite	Räder

- TELAIO PROFILATO TUBOLARE DI GROSSO SPESSORE ZINCATO A CALDO
- SUPPORTI PARAFANGHI CALPESTABILI
- BARRA FANALERIA IN ALLUMINIO / A SMONTAGGIO RAPIDO
- PERNO A MOLLA DI SICUREZZA PER EVITARE FUORIUSCITA FANALERIA
- IMPIANTO ELETTRICO PARZIALMENTE INTERNO AL TELAIO
- RUOTINO DI STAZIONAMENTO ZINCATO A CALDO CON CUSCINETTO PER MINIMO SFORZO IN ALZATA

- THICK, HOT-DIP GALVANIZED TUBULAR PROFILED CHASSIS
- WALK-ON MUD GUARD SUPPORTS
- ALUMINIUM LIGHTING BAR / QUICK TO DISASSEMBLE
- SAFETY SPRING PIN TO PREVENT THE LIGHTING FROM COMING OUT
- ELECTRICAL SYSTEM PARTLY INSIDE THE CHASSIS
- HOT-DIP GALVANISED PARKING BRAKE WITH BEARING FOR MINIMAL STRAIN

- CHÂSSIS PROFILÉ TUBULAIRE DE GROSSE ÉPAISSEUR GALVANISÉ À CHAUD
- SUPPORTS GARDE-BOUE CIRCULABLES
- BARRE D'ÉCLAIRAGE EN ALUMINIUM / À DÉMONTAGE RAPIDE
- GOUPILE DE SÉCURITÉ À RESSORT POUR ÉVITER LE GLISSEMENT DE LA BARRE D'ÉCLAIRAGE
- INSTALLATION ÉLECTRIQUE PARTIELLEMENT INTÉGRÉE AU CHÂSSIS
- ROUE JOCKEY DE STATIONNEMENT GALVANISÉE À CHAUD AVEC COUSSINET POUR UN EFFORT MINIMUM EN LEVÉE

- PROFILRAHMEN AUS STARKEN, FEUERVERZINKTEN ROHREN
- BEGEBBARE KOTFLÜGELHALTERUNGEN
- BELEUCHTUNGSLEISTE AUS ALUMINIUM / SCHNELL ABBAUBAR
- FEDERSTIFT ZUM SICHERN DER BELEUCHTUNG INTEGRIERT
- ELEKTROANLAGE ZUM TEIL IN DEN RAHMEN INTEGRIERT
- FEUERVERZINKTES FESTSTELLRAD MIT LAGER FÜR MINIMALE ANSTRENGUNG BEIM ANHEBEN

PER INFORMAZIONI E PREZZI POTETE CONSULTARE IL NOSTRO SITO INTERNET OPPURE RIVOLGERVI PRESSO UN RIVENDITORE DI ZONA. Per tutti i modelli la ruota di scorta è optional. Dati e misure del presente catalogo sono semplicemente indicativi e non impegnativi. La ditta si riserva qualsiasi modifica senza preavviso.

- R- Attrezzato con rulli, argano e fermaprua
- R- Equipped with rollers, winch and bow stop
- R- Equipé de rouleaux, treuil et cale de proue
- R- Ausgestattet mit walzen, winde und bughalter

**CUSCINETTI
STAGNI
GUAINE FRENO
IN INOX**

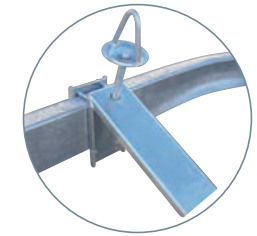

OPTIONAL



OPTIONAL

- Traversa posteriore basculante di serie (multirullo)
- Tilting rear cross member as standard (multi-roller)
- Traverse arrière basculante de série (multi-rouleaux)
- Serienmäßiger hinterer kipparer querbalken (mehrere walzen)

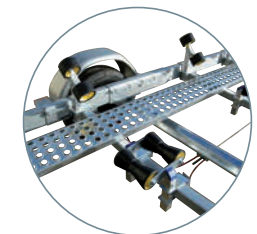
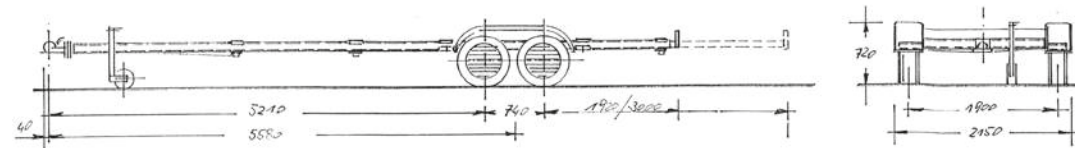

OPTIONAL

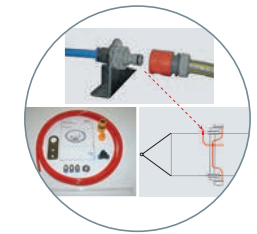

OPTIONAL

N2700-R-	2700/2500/2300/2000/1800/1600 Kg	2160/1960/1760/1460/1260/1060 Kg	2055/1855/1655/1355/1155/955 Kg	899 - 791 cm	215 cm	185 R 14C
	Peso a pieno carico	Portata utile senza attrezzatura	Portata utile con attrezzatura standard	Lunghezza max e min.	Larghezza max	Ruote
	Full load weight	Capacity without equipment	Capacity with standard equipment	Max and min length	Width	Wheels
	Poids total en charge	Charge utile sans équipement	Charge utile avec équipement standard	Longueur max et min	Largeur max	Roues
	Zulässiges Gesamtgewicht	Nutzlast ohne Ausrüstung	Nutzlast mit Standardausrüstung	Min und Max. länge	Max. Breite	Räder

- TELAIO PROFILATO TUBOLARE DI GROSSO SPESSORE ZINCATO A CALDO
- SUPPORTI PARAFANGHI CALPESTABILI
- BARRA FANALERIA IN ALLUMINIO / A SMONTAGGIO RAPIDO
- PERNO A MOLLA DI SICUREZZA PER EVITARE FUORIUSCITA FANALERIA
- IMPIANTO ELETTRICO PARZIALMENTE INTERNO AL TELAIO
- RUOTINO DI STAZIONAMENTO ZINCATO A CALDO CON CUSCINETTO PER MINIMO SFORZO IN ALZATA

- THICK, HOT-DIP GALVANIZED TUBULAR PROFILED CHASSIS
- WALK-ON MUD GUARD SUPPORTS
- ALUMINIUM LIGHTING BAR / QUICK TO DISASSEMBLE
- SAFETY SPRING PIN TO PREVENT THE LIGHTING FROM COMING OUT
- ELECTRICAL SYSTEM PARTLY INSIDE THE CHASSIS
- HOT-DIP GALVANISED PARKING BRAKE WITH BEARING FOR MINIMAL STRAIN

- CHÂSSIS PROFILÉ TUBULAIRE DE GROSSE ÉPAISSEUR GALVANISÉ À CHAUD
- SUPPORTS GARDE-BOUE CIRCULABLES
- BARRÉ D'ÉCLAIRAGE EN ALUMINIUM / À DÉMONTAGE RAPIDE
- GOUPILLE DE SÉCURITÉ À RESSORT POUR ÉVITER LE GLISSEMENT DE LA BARRÉ D'ÉCLAIRAGE
- INSTALLATION ÉLECTRIQUE PARTIELLEMENT INTÉGRÉE AU CHÂSSIS
- ROUE JOCKEY DE STATIONNEMENT GALVANISÉE À CHAUD AVEC COUSSINET POUR UN EFFORT MINIMUM EN LÈVÉ

- PROFILRAHMEN AUS STARKEN, FEUERVERZINKTEN ROHREN
- BEGEBBARE KOTFLÜGELHALTERUNGEN
- BELEUCHTUNGSLEISTE AUS ALUMINIUM / SCHNELL ABBAUBAR
- FEDERSTIFT ZUM SICHERN DER BELEUCHTUNG
- ELEKTROANLAGE ZUM TEIL IN DEN RAHMEN INTEGRIERT
- FEUERVERZINKTES FESTSTELLRAD MIT LAGER FÜR MINIMALE ANSTRENGUNG BEIM ANHEBEN

PER INFORMAZIONI E PREZZI POTETE CONSULTARE IL NOSTRO SITO INTERNET OPPURE RIVOLGERVI PRESSO UN RIVENDITORE DI ZONA. Per tutti i modelli la ruota di scorta è optional. Dati e misure del presente catalogo sono semplicemente indicativi e non impegnativi. La ditta si riserva qualsiasi modifica senza preavviso.



- R- Attrezzato con rulli, argano e fermaprua
- R- Equipped with rollers, winch and bow stop
- R- Équipé de rouleaux, treuil et cale de proue
- R- Ausgestattet mit walzen, winde und bughalter

**CUSCINETTI
STAGNI
GUAINE FRENO
IN INOX**

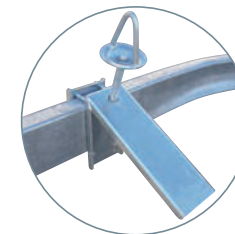

OPTIONAL



OPTIONAL

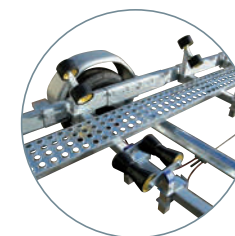

OPTIONAL

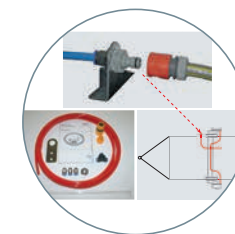

OPTIONAL

- Traversa posteriore basculante di serie (multirullo)
- Tilting rear cross member as standard (multi-roller)
- Traverse arrière basculante de série (multi-rouleaux)
- Serienmäßiger hinterer kipbarer Querbalken (mehrere walzen)

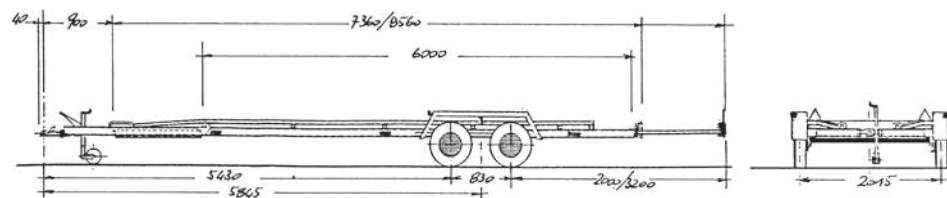

N3000-R-	3000/2700/2500/2300/2000/1800/ 1600 Kg	2460/2160/1960/1760/1460/1260/ 1060 Kg	2345/2045/1845/1645/1345/1145 /945 Kg	950 - 830 cm	222 cm	185 R 14C
	Peso a pieno carico Full load weight Poids total en charge Zulässiges Gesamtgewicht	Portata utile senza attrezzatura Capacity without equipment Charge utile sans équipement Nutzlast ohne Ausrüstung	Portata utile con attrezzatura standard Capacity with standard equipment Charge utile avec équipement standard Nutzlast mit Standardausrüstung	Lunghezza max e min. Max and min lenght Longueur max et min Min und Max. länge	Larghezza max Width Largeur max Max. Breite	Ruote Wheels Roues Räder

- TELAIO PROFILATO TUBOLARE DI GROSSO SPESSORE ZINCATO A CALDO
- SUPPORTI PARAFANGHI CALPESTABILI
- BARRA FANALERIA IN ALLUMINIO / A SMONTAGGIO RAPIDO
- PERNO A MOLLA DI SICUREZZA PER EVITARE FUORIUSCITA FANALERIA
- IMPIANTO ELETTRICO PARZIALMENTE INTERNO AL TELAIO
- RUOTINO DI STAZIONAMENTO ZINCATO A CALDO CON CUSCINETTO PER MINIMO SFORZO IN ALZATA

- THICK, HOT-DIP GALVANIZED TUBULAR PROFILED CHASSIS
- WALK-ON MUD GUARD SUPPORTS
- ALUMINIUM LIGHTING BAR / QUICK TO DISASSEMBLE
- SAFETY SPRING PIN TO PREVENT THE LIGHTING FROM COMING OUT
- ELECTRICAL SYSTEM PARTLY INSIDE THE CHASSIS
- HOT-DIP GALVANISED PARKING BRAKE WITH BEARING FOR MINIMAL STRAIN

- CHÂSSIS PROFILÉ TUBULAIRE DE GROSSE ÉPAISSEUR GALVANISÉ À CHAUD
- SUPPORTS GARDE-BOUE CIRCULABLES
- BARRE D'ÉCLAIRAGE EN ALUMINIUM / À DÉMONTAGE RAPIDE
- GOUPILE DE SÉCURITÉ À RESSORT POUR ÉVITER LE GLISSEMENT DE LA Barre D'ÉCLAIRAGE
- INSTALLATION ÉLECTRIQUE PARTIELLEMENT INTÉGRÉE AU CHÂSSIS
- ROUE JOCKEY DE STATIONNEMENT GALVANISÉE À CHAUD AVEC COUSSINET POUR UN EFFORT MINIMUM EN LEVÉE

- PROFILRAHMEN AUS STARKEN, FEUERVERZINKTEN ROHREN
- BEGEBHARE KOTFLÜGELHALTERUNGEN
- BELEUCHTUNGSLEISTE AUS ALUMINIUM / SCHNELL ABBAUBAR
- FEDERSTIFT ZUM SICHERN DER BELEUCHTUNG
- ELEKTROANLAGE ZUM TEIL IN DEN RAHMEN INTEGRIERT
- FEUERVERZINKTES FESTSTELLRAD MIT LAGER FÜR MINIMALE ANSTRENGUNG BEIM ANHEBEN

PER INFORMAZIONI E PREZZI POTETE CONSULTARE IL NOSTRO SITO INTERNET OPPURE RIVOLGERVI PRESSO UN RIVENDITORE DI ZONA. Per tutti i modelli la ruota di scorta è optional. Dati e misure del presente catalogo sono semplicemente indicativi e non impegnativi. La ditta si riserva qualsiasi modifica senza preavviso.



- R- Attrezzato con rulli, argano e fermaprua
- R- Equipped with rollers, winch and bow stop
- R- Équipé de rouleaux, treuil et cale de proue
- R- Ausgestattet mit walzen, winde und bughalter

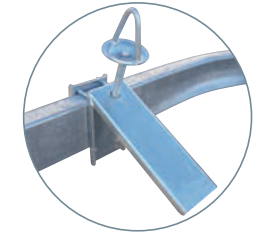

OPTIONAL



OPTIONAL

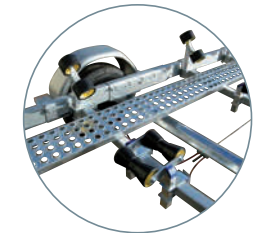

OPTIONAL

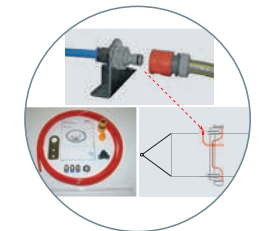

OPTIONAL

Traversa posteriore basculante di serie (multirullo)
 Tilting rear cross member as standard (multi-roller)
 Traversa arrière basculante de série (multi-rouleaux)
 Serienmäßiger hinterer kipbarer Querbalken (mehrere walzen)

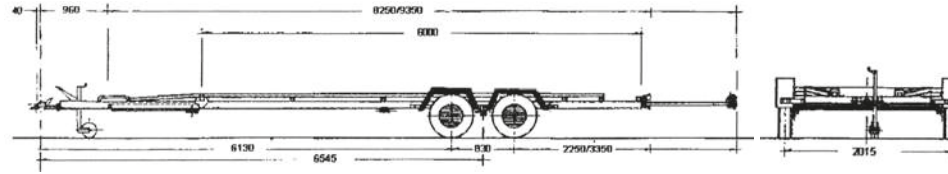

N3000L-R-	3000/2700/2500/2300/2000/1800/ 1600 Kg	2410/2110/1910/1710/1410/ 1210/1010 Kg	2295/1995/1795/1595/1295/ 1095/895 Kg	1035 - 925 cm	222 cm	185 R 14C
	Peso a pieno carico Full load weight Poids total en charge Zulässiges Gesamtgewicht	Portata utile senza attrezzatura Capacity without equipment Charge utile sans équipement Nutzlast ohne Ausrüstung	Portata utile con attrezzatura standard Capacity with standard equipment Charge utile avec équipement standard Nutzlast mit Standardausrüstung	Lunghezza max e min. Max and min length Longueur max et min Min und Max. länge	Larghezza max Width Largeur max Max. Breite	Ruote Wheels Roues Räder

- TELAIO PROFILATO TUBOLARE DI GROSSO SPESORE ZINCATO A CALDO
- SUPPORTI PARAFANGHI CALPESTABILI
- BARRA FANALERIA IN ALLUMINIO / A SMONTAGGIO RAPIDO
- PERNO A MOLLA DI SICUREZZA PER EVITARE FUORIUSCITA FANALERIA
- IMPIANTO ELETTRICO PARZIALMENTE INTERNO AL TELAIO
- RUOTINO DI STAZIONAMENTO ZINCATO A CALDO CON CUSCINETTO PER MINIMO SFORZO IN ALZATA

- THICK, HOT-DIP GALVANIZED TUBULAR PROFILED CHASSIS
- WALK-ON MUD GUARD SUPPORTS
- ALUMINIUM LIGHTING BAR / QUICK TO DISASSEMBLE
- SAFETY SPRING PIN TO PREVENT THE LIGHTING FROM COMING OUT
- ELECTRICAL SYSTEM PARTLY INSIDE THE CHASSIS
- HOT-DIP GALVANISED PARKING BRAKE WITH BEARING FOR MINIMAL STRAIN

- CHÂSSIS PROFILÉ TUBULAIRE DE GROSSE ÉPAISSEUR GALVANISÉ À CHAUD
- SUPPORTS GARDE-BOUE CIRCULABLES
- BARRÉ D'ÉCLAIRAGE EN ALUMINIUM / À DÉMONTAGE RAPIDE
- GOUPILLE DE SÉCURITÉ À RESSORT POUR ÉVITER LE GLISSEMENT DE LA BARRÉ D'ÉCLAIRAGE
- INSTALLATION ÉLECTRIQUE PARTIELLEMENT INTÉGRÉE AU CHÂSSIS
- ROUE JOCKEY DE STATIONNEMENT GALVANISÉE À CHAUD AVEC COUSSINET POUR UN EFFORT MINIMUM EN LÈVÉE

- PROFILRAHMEN AUS STARKEN, FEUERVERZINKTEN ROHREN
- BEGEBBARE KOTFLÜGELHALTERUNGEN
- BELEUCHTUNGSLEISTE AUS ALUMINIUM / SCHNELL ABBAUBAR
- FEDERSTIFT ZUM SICHERN DER BELEUCHTUNG
- ELEKTROANLAGE ZUM TEIL IN DEN RAHMEN INTEGRIERT
- FEUERVERZINKTES FESTSTELLRAD MIT LAGER FÜR MINIMALE ANSTRENGUNG BEIM ANHEBEN

PER INFORMAZIONI E PREZZI POTETE CONSULTARE IL NOSTRO SITO INTERNET OPPURE RIVOLGERVI PRESSO UN RIVENDITORE DI ZONA. Per tutti i modelli la ruota di scorta è optional. Dati e misure del presente catalogo sono semplicemente indicativi e non impegnativi. La ditta si riserva qualsiasi modifica senza preavviso.



- R- Attrezzato con rulli, argano e fermaprua
- R- Equipped with rollers, winch and bow stop
- R- Equipé de rouleaux, treuil et cale de proue
- R- Ausgestattet mit walzen, winde und bughalter



- Traversa posteriore basculante di serie (multirullo)
- Tilting rear cross member as standard (multi-roller)
- Traverse arrière basculante de série (multi-rouleaux)
- Serienmäßiger hinterer kipparer querbalken (mehrere walzen)

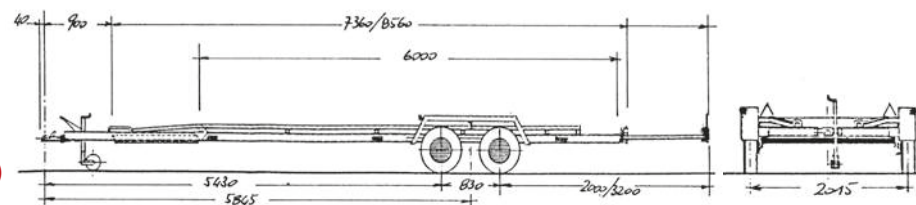

N3500-R-	3495/3000/2700 Kg	2885/2390/2090 Kg	2770/2275/1975 Kg	950 - 830 cm	222 cm	185 R 14C
	Peso a pieno carico	Portata utile senza attrezzatura	Portata utile con attrezzatura standard	Lunghezza max e min	Larghezza max	Ruote
	Full load weight	Capacity without equipment	Capacity with standard equipment	Max and min length	Width	Wheels
	Poids total en charge	Charge utile sans équipement	Charge utile avec équipement standard	Longueur max et min	Largueur max	Roues
	Zulässiges Gesamtgewicht	Nutzlast ohne Ausrüstung	Nutzlast mit Standardausrüstung	Min und Max. länge	Max. Breite	Räder

- TELAIO PROFILATO TUBOLARE DI GROSSO SPESSORE ZINCATO A CALDO
- SUPPORTI PARAFANGHI CALPESTABILI
- BARRA FANALERIA IN ALLUMINIO / A SMONTAGGIO RAPIDO
- PERNO A MOLLA DI SICUREZZA PER EVITARE FUORIUSCITA FANALERIA
- IMPIANTO ELETTRICO PARZIALMENTE INTERNO AL TELAIO
- RUOTINO DI STAZIONAMENTO ZINCATO A CALDO CON CUSCINETTO PER MINIMO SFORZO IN ALZATA

- THICK, HOT-DIP GALVANIZED TUBULAR PROFILED CHASSIS
- WALK-ON MUD GUARD SUPPORTS
- ALUMINIUM LIGHTING BAR / QUICK TO DISASSEMBLE
- SAFETY SPRING PIN TO PREVENT THE LIGHTING FROM COMING OUT
- ELECTRICAL SYSTEM PARTLY INSIDE THE CHASSIS
- HOT-DIP GALVANISED PARKING BRAKE WITH BEARING FOR MINIMAL STRAIN

- CHÂSSIS PROFILÉ TUBULAIRE DE GROSSE ÉPAISSEUR GALVANISÉ À CHAUD
- SUPPORTS GARDE-BOUE CIRCULABLES
- BARRE D'ÉCLAIRAGE EN ALUMINIUM / À DÉMONTAGE RAPIDE
- GOUPILLE DE SÉCURITÉ À RESSORT POUR ÉVITER LE GLISSEMENT DE LA BARRE D'ÉCLAIRAGE
- INSTALLATION ÉLECTRIQUE PARTIELLEMENT INTÉGRÉE AU CHÂSSIS
- ROUE JOCKEY DE STATIONNEMENT GALVANISÉE À CHAUD AVEC COUSSINET POUR UN EFFORT MINIMUM EN LEVÉE

- PROFILRAHMEN AUS STARKEN, FEUERVERZINKTEN ROHREN
- BEGEBHARE KOTFLÜGELHALTERUNGEN
- BELEUCHTUNGSLEISTE AUS ALUMINIUM / SCHNELL ABBAUBAR
- FEDERSTIFT ZUM SICHERN DER BELEUCHTUNG
- ELEKTROANLAGE ZUM TEIL IN DEN RAHMEN INTEGRIERT
- FEUERVERZINKTES FESTSTELLRAD MIT LAGER FÜR MINIMALE ANSTRENGUNG BEIM ANHEBEN

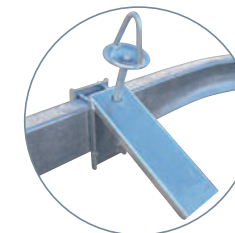

OPTIONAL

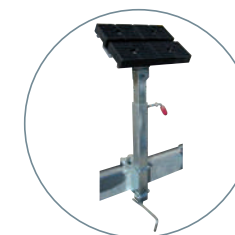

OPTIONAL

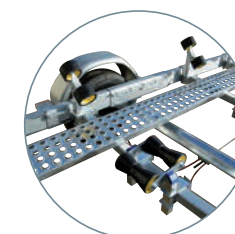

OPTIONAL

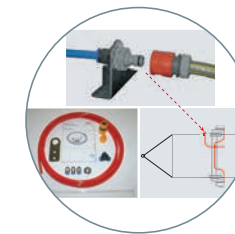

OPTIONAL

PER INFORMAZIONI E PREZZI POTETE CONSULTARE IL NOSTRO SITO INTERNET OPPURE RIVOLGERVI PRESSO UN RIVENDITORE DI ZONA. Per tutti i modelli la ruota di scorta è optional. Dati e misure del presente catalogo sono semplicemente indicativi e non impegnativi. La ditta si riserva qualsiasi modifica senza preavviso.



- R- Attrezzato con rulli, argano e fermaprua
- R- Equipped with rollers, winch and bow stop
- R- Équipé de rouleaux, treuil et cale de proue
- R- Ausgestattet mit walzen, winde und bughalter

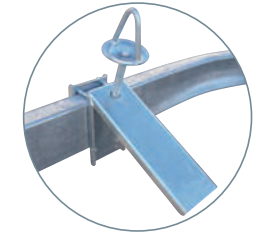

OPTIONAL



OPTIONAL

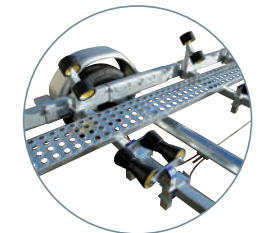

OPTIONAL

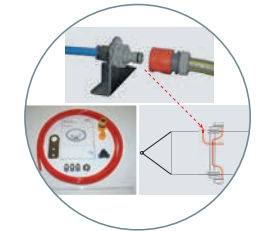

OPTIONAL

- Traversa posteriore basculante di serie (multirullo)
- Tilting rear cross member as standard (multi-roller)
- Traverse arrière basculante de série (multi-rouleaux)
- Serienmäßiger hinterer kipbarer querbalken (mehrere walzen)

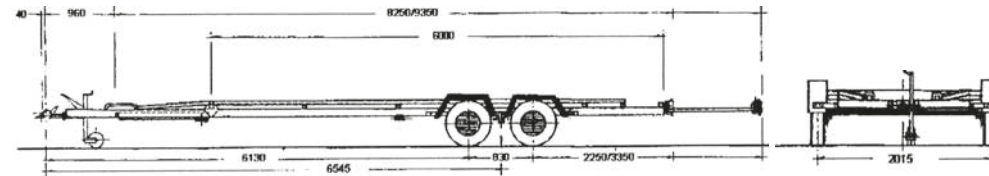

N3500L-R-	3495/3000/2700 Kg	2825/2330/2030 Kg	2710/2215/1915 Kg	1035 - 925 cm	222 cm	185 R 14C
Peso a pieno carico	Full load weight	Portata utile senza attrezzatura	Capacity without equipment	Lunghezza max e min.	Larghezza max	Ruote
Full load weight		Capacity without equipment	Capacity with standard equipment	Max and min length	Width	Wheels
Poids total en charge		Charge utile sans équipement	Charge utile avec équipement standard	Longueur max et min	Largueur max	Roues
Zulässiges Gesamtgewicht		Nutzlast ohne Ausrüstung	Nutzlast mit Standardausrüstung	Min und Max. länge	Max. Breite	Räder

- TELAIO PROFILATO TUBOLARE DI GROSSO SPESSORE ZINCATO A CALDO
- SUPPORTI PARAFANGHI CALPESTABILI
- BARRA FANALERIA IN ALLUMINIO / A SMONTAGGIO RAPIDO
- PERNO A MOLLA DI SICUREZZA PER EVITARE FUORIUSCITA FANALERIA
- IMPIANTO ELETTRICO PARZIALMENTE INTERNO AL TELAIO
- RUOTINO DI STAZIONAMENTO ZINCATO A CALDO CON CUSCINETTO PER MINIMO SFORZO IN ALZATA

- THICK, HOT-DIP GALVANIZED TUBULAR PROFILED CHASSIS
- WALK-ON MUD GUARD SUPPORTS
- ALUMINIUM LIGHTING BAR / QUICK TO DISASSEMBLE
- SAFETY SPRING PIN TO PREVENT THE LIGHTING FROM COMING OUT
- ELECTRICAL SYSTEM PARTLY INSIDE THE CHASSIS
- HOT-DIP GALVANISED PARKING BRAKE WITH BEARING FOR MINIMAL STRAIN

- CHÂSSIS PROFILÉ TUBULAIRE DE GROSSE ÉPAISSEUR GALVANISÉ À CHAUD
- SUPPORTS GARDE-BOUE CIRCULABLES
- RAMPE D'ÉCLAIRAGE EN ALUMINIUM / À DÉMONTAGE RAPIDE
- GOUPILLE DE SÉCURITÉ À RESSORT POUR ÉVITER LE GLISSEMENT DE LA RAMPE D'ÉCLAIRAGE
- INSTALLATION ÉLECTRIQUE PARTIELLEMENT INTÉGRÉE AU CHÂSSIS
- ROUE JOCKEY DE STATIONNEMENT GALVANISÉE À CHAUD AVEC COUSSINET POUR UN EFFORT MINIMUM EN LÈVÉE

- PROFILRAHMEN AUS STARKEN, FEUERVERZINKTEN ROHREN
- BEGEBBARE KOTFLÜGELHALTERUNGEN
- BELEUCHTUNGSLEISTE AUS ALUMINIUM / SCHNELL ABBAUBAR
- FEDERSTIFT ZUM SICHERN DER BELEUCHTUNG
- ELEKTROANLAGE ZUM TEIL IN DEN RAHMEN INTEGRIERT
- FEUERVERZINKTES FESTSTELLRAD MIT LAGER FÜR MINIMALE ANSTRENGUNG BEIM ANHEBEN

PER INFORMAZIONI E PREZZI POTETE CONSULTARE IL NOSTRO SITO INTERNET OPPURE RIVOLGERVI PRESSO UN RIVENDITORE DI ZONA. Per tutti i modelli la ruota di scorta è optional. Dati e misure del presente catalogo sono semplicemente indicativi e non impegnativi. La ditta si riserva qualsiasi modifica senza preavviso.

MOSSO

GROUP

MOSSO GROUP

RIVENDITORE AUTORIZZATO

Via Villa Cristina, 60

10093 Collegno (TO) - Italy

Tel: 011 424 0024

www.mossogroup.it

info@mossogroup.it